

2005-06 BUICK TERRAZA
2005-06 CHEVROLET UPLANDER
2005-06 PONTIAC MONTANA SV6
2005-06 SATURN RELAY

DASH DISASSEMBLY INSTRUCTIONS

1. Carefully unclip the trim from around the radio/Climate controls and remove. (Use of a panel removal tool, or a right angle scribe tool is recommended).
2. Remove the (8) 9/32 or Phillips screws securing the Radio and Climate controls to the sub-dash.
3. Pull the Radio and Climate controls forward, lower and set the climate control out of the way, disconnect the wire harnesses and antenna lead from the rear of the factory radio and remove radio.

2005-06 HUMMER H3

DASH DISASSEMBLY

1. Carefully remove trim from around radio.
2. Remove (4) 9/32 screws securing factory radio and climate controls to the sub-dash.
3. Lay climate controls out of the way.
4. Pull radio and climate controls forward, disconnect all harnesses from radio and remove radio.

DIN MOUNT INSTALLATION INSTRUCTIONS

1. Insert DIN sleeve from your new radio into the radio opening of the installation kit.
2. Depress the tabs from inside the sleeves opening upward, outward, and downward to secure sleeve to the installation kit.

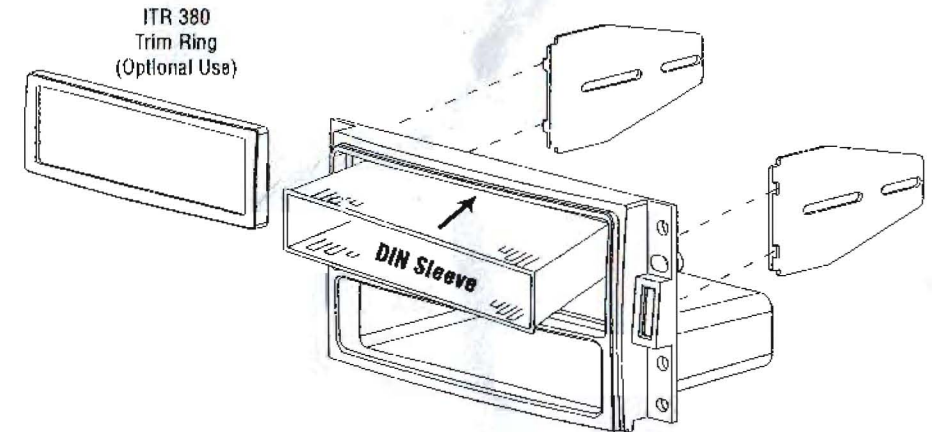

ISO MOUNT INSTALLATION INSTRUCTIONS

1. Attach ISO brackets to the rear of the main mounting kit (see illustration above).
2. Slide radio into kit from rear & attach to ISO mounting brackets using screws supplied with radio (do not tighten screws at this time).
3. Slide radio forward or backward for your desired look and then tighten the mounting screws. Use ISO trim ring when possible.
4. Attach rear support strap (supplied with radio) to rear of pocket and to rear of radio.

