

Installation Manual Double DIN Kit



Colour: black
part-no.: 381170-05

- Mazda MX-5 (NC1/NC1E) 2006 ->
- Mazda Miata (US-Version only) 2006 ->

Compatible with these devices

Double-DIN Navigation

- (1) Radio Housing
- (2) Double DIN brackets
- (3) Snap in pocket
- (4) ISO trim plate
- (5) Panel clips
- (6) ISO brackets
- (7) Double DIN trim plate

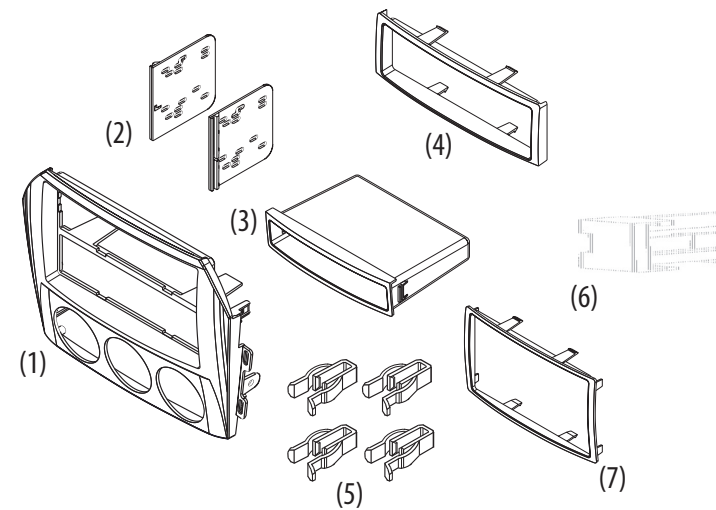

Dash Disassembly

- 1 Disconnect the negative battery terminal to prevent an accidental short circuit.
- 2 Unclip panel below steering column and remove. (Figure A)
- 3 Remove (4) Phillips screws from metal brace below steering column and remove. (Figure A)
- 4 Looking at the side of the radio/climate control panel from underneath the steering column opening, remove (1) 10mm bolt from the side of the radio chassis. (Figure B)
- 5 Carefully remove the side panels from each side of the radio/climate control panel by pulling straight back towards the rear of the car. (Figure C)

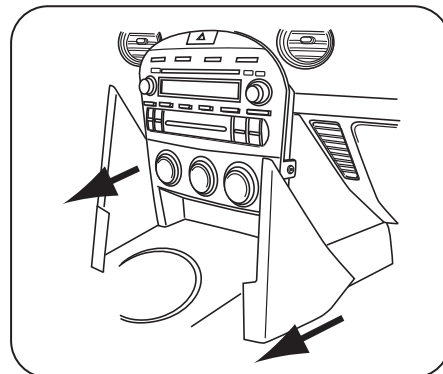
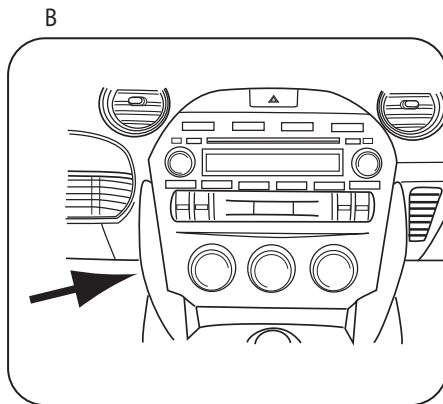
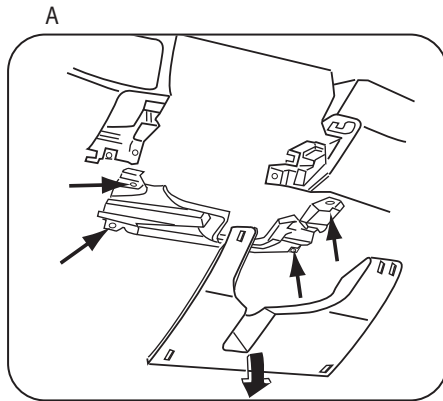

Double-ISO DIN Head Unit Provision

- 1 Turn over the housing, take the climate control and screws removed from the factory panel and attach the climate control to the kit housing using the factory screws. (Figure A)
- 2 Cut the rib in the middle of the housing to make room for the DDIN brackets. (Figure A)
- 3 Slide the appropriate DDIN bracket into the kit housing. (Figure B)
- 4 Slide the stacked ISO DIN units into the DDIN bracket assembly and secure the units to the kit using the screws supplied with the head units. (Figure C)
- 5 Snap the DDIN trim plate into the front of the kit housing. (Figure C)

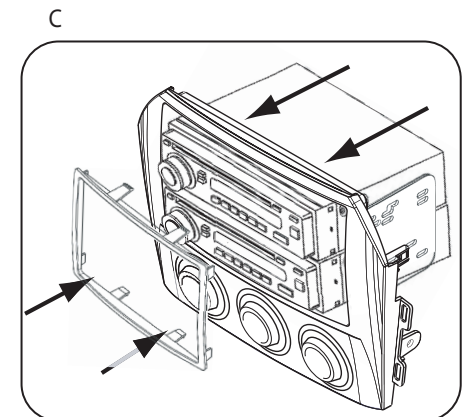
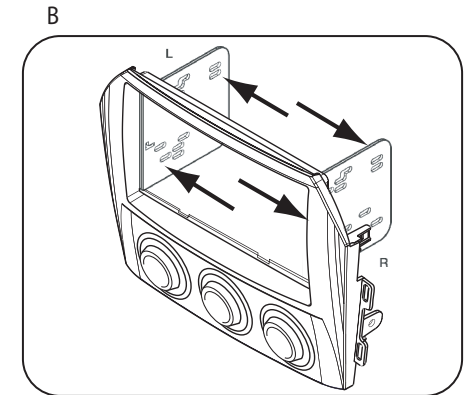
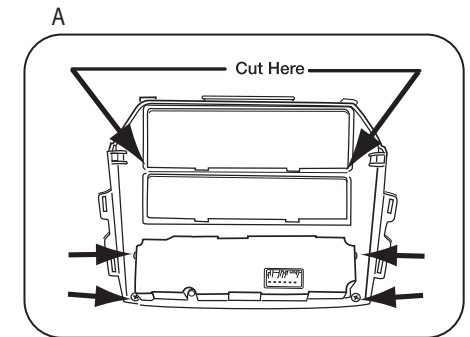

1-DIN Head Unit Provision

- 1 Turn over the housing, take the climate control and screws removed from the factory panel and attach the climate control to the kit housing using the factory screws. (Figure A)

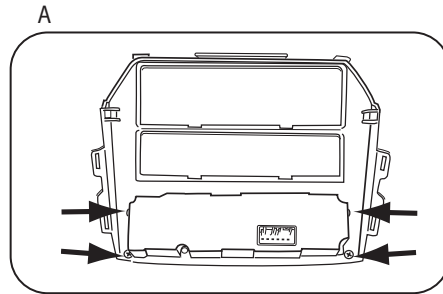

- 2 Slide the pocket into the bottom section of the kit housing. (Figure B)

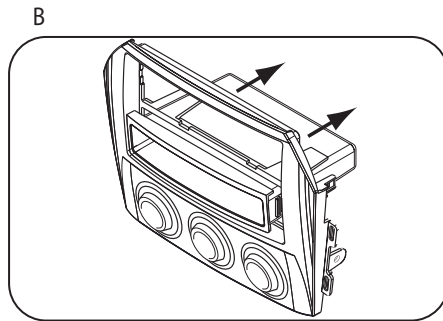

- 3 Mount the ISO Brackets to the head unit with the screws supplied with the unit. (Figure C)

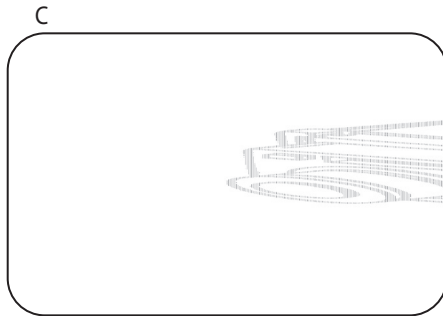

- 4 Slide the head unit into the radio opening until the side clips engage. (Figure D)

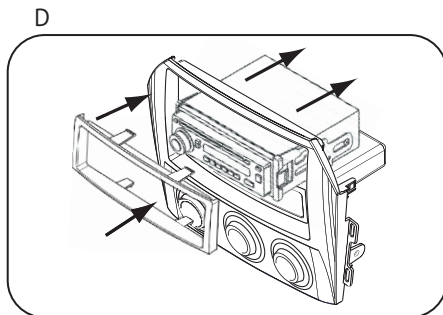

- 5 Snap the Trim plate into the Radio Housing. (Figure E)

Double DIN Head Unit Provision

- 6 Remove (2) Phillips screws, (1) on each side, from the side of the radio/climate control panel. (Figure D)

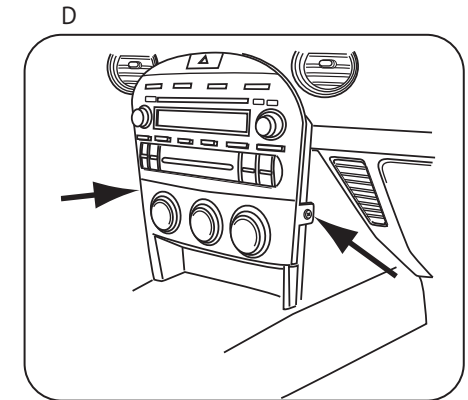

- 7 Pull radio/climate control panel out, disconnect plugs and remove. (Figure E)

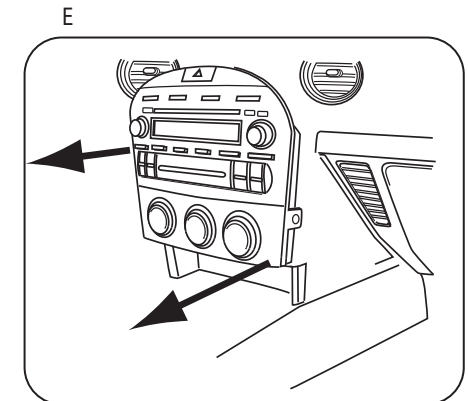

- 8 Turn the radio/climate control panel over and remove the (4) screws that hold the climate control to the bezel, then remove the climate control. (Figure F)

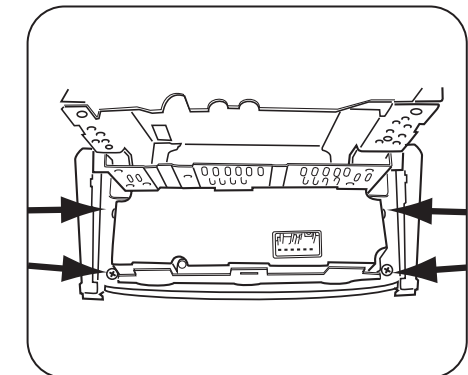

Kit Preparation

- 9 Attach the (4) Panel Clips to the posts on the back of the radio housing. (Figure A)

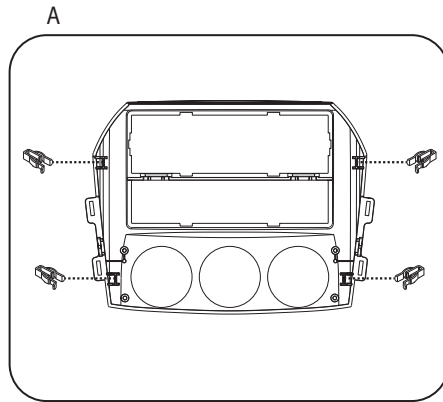

Double DIN Head Unit Provision

- 10 Turn over the housing, take the climate control and screws removed from the factory panel and attach the climate control to the kit housing using the factory screws. (Figure A)
- 11 Cut the rib in the middle of the housing to make room for the DDIN brackets. (Figure A)

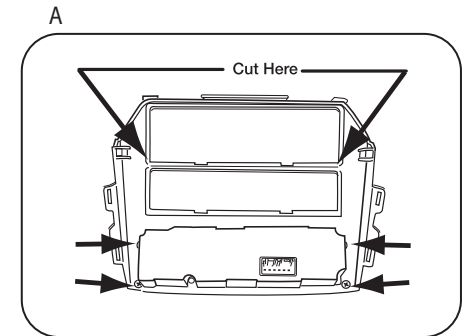

- 12 Slide the appropriate DDIN bracket into the kit housing. (Figure B)

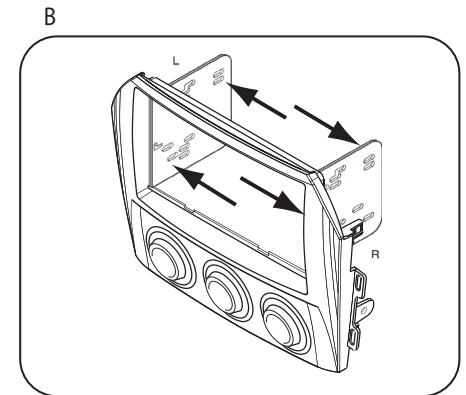

- 13 Slide the DDIN radio unit into DDIN brackets and secure the unit to the kit using the screws supplied with the head unit. (Figure C)

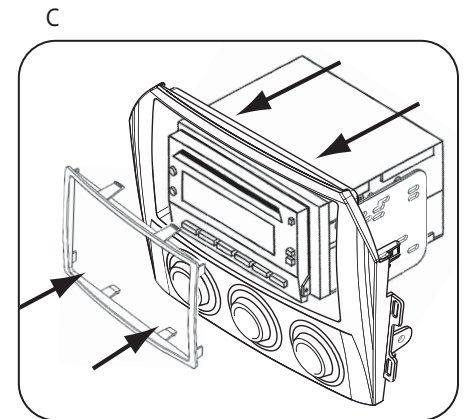

- 14 Snap the DDIN trim plate into the front of the kit housing. (Figure C)