



Installation Manual Double DIN Kit

Ford Focus 2011->

Colour: black

Lead Cable for	part-no.:		
Alpine	381114-23-1-1	Kenwood	381114-23-1-7
Blaupunkt	381114-23-1-5	Panasonic	381114-23-1-2
Becker	381114-23-1-0	Pioneer	381114-23-1-3
Clarion	381114-23-1-8	Sony	381114-23-1-6
JVC	381114-23-1-9	Zenec	381114-23-1-4

Compatible with these double DIN devices

Double DIN Navigation

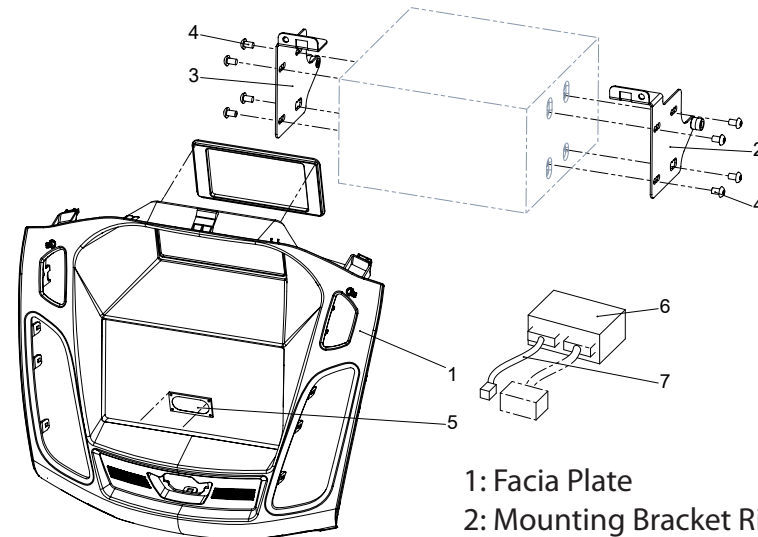

- 1: Facia Plate
- 2: Mounting Bracket Right Assembly
- 3: Mounting Bracket Left Assembly
- 4: Flat Headed Screw
- 5: Speaker
- 6: Stalk Interface
- 7: Lead Cable

*Spare OEM hazard light
switch by Ford required
Ford Part-No.: 1519127*



1. Ford Focus OEM Dashboard
(sample photo)

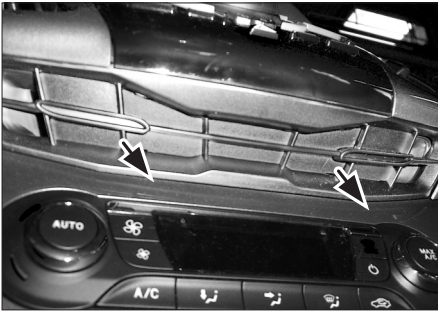

2. Unclip panel under OEM radio

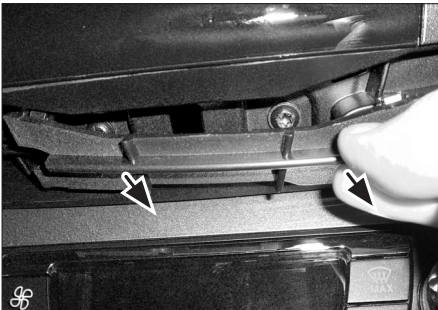

3. Remove Panel under OEM radio

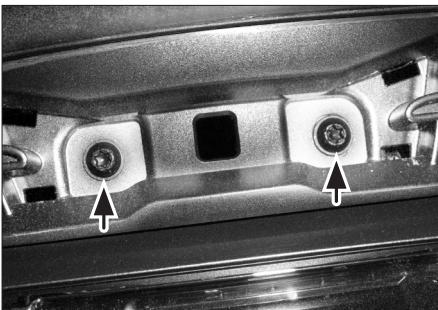

4. These 2 screws need to
be removed

*All installation work must be performed by a qualified professional installer only.
The manufacturer / dealer is not liable for any kind of incidental or indirect damages.*

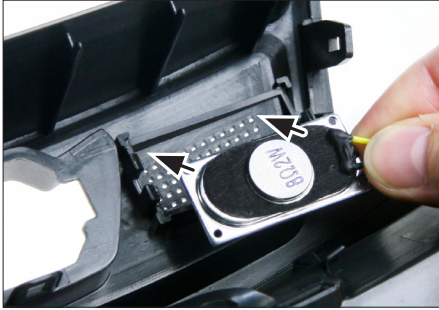

14. as needed fix speaker with cyanoacrylate adhesive

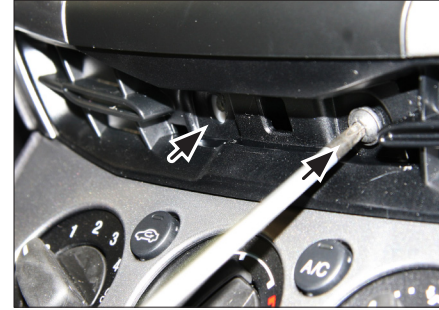

4a. Remove 2 screws under OEM radio



15. A spare OEM hazard light switch by Ford is required.

Ford Part-No.: 1519127



5. Unclip OEM panel



16. Mount spare hazard light switch to fascia plate. Clip fascia plate on dash board. Install everything in reverse order.



6. Remove OEM panel carefully

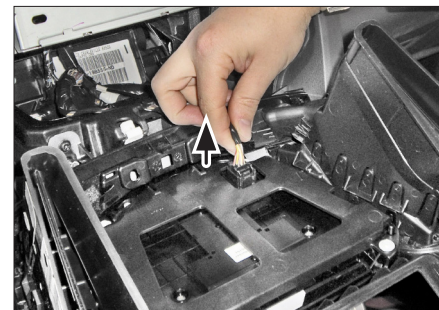

7. Unplug cables

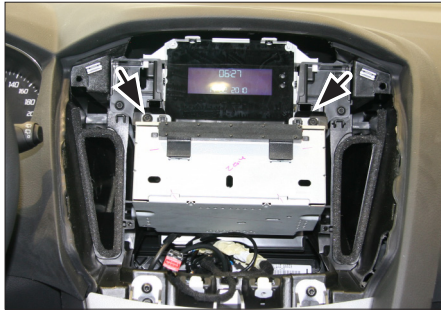

- 8. Remove 2 screws (see arrows)
Remove OEM head unit

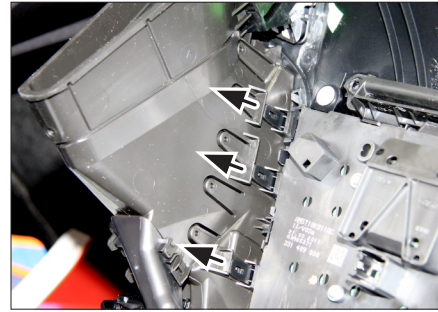
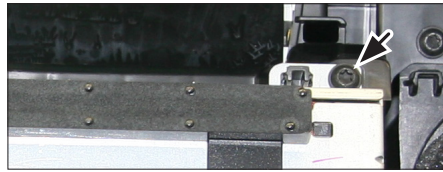

Preperation of facia plate

- 12. Unclip 2 OEM air vents



- 9. OEM dash board with removed head unit

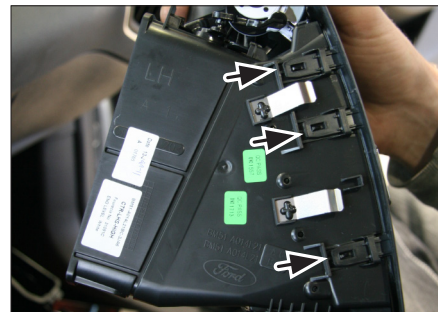

Preperation of facia plate

- 13. Mount them to new facia plate

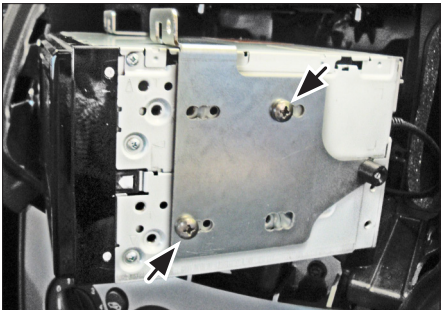

- 10. Mount mounting brackets to double DIN head unit



The Focus is equipped with two kinds of OEM displays

A: Display with 2 buttons at right side (see arrow)

No trim frame required



- 11. Install double DIN head unit

Connect all required circuit points and connections. Please see stalk interface manual for connecting stalk interface

Fix navigation with OEM screws



B: Colour Display:

Clip trim frame to facia plate

