

1. Locate the factory wiring harness in the dash. Re-connect the negative battery terminal and test the unit for proper operation.

2. Slide the Double DIN head unit into the brackets and secure the Double DIN head unit to the assembly using the screws supplied with the radio. (Figure B)

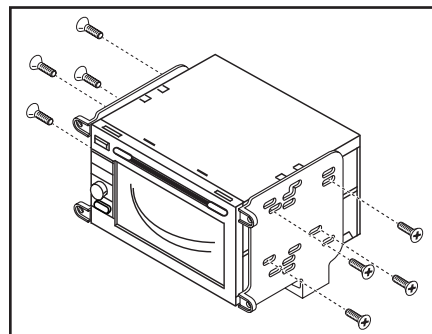

(Figure B)

3. Secure the radio housing brackets to the radio housing with four #8X3/8" Phillips screws provided. (Figure C)

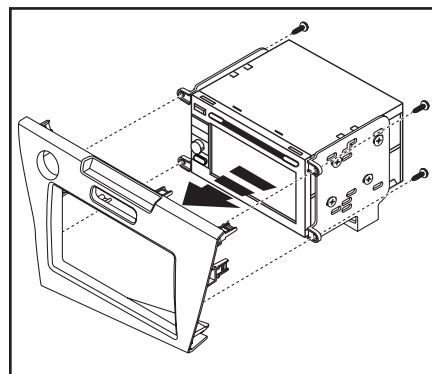

(Figure C)

4. Reassemble dash in reverse order of disassembly using the supplied #8 screw in place of the factory screw removed in step one, figure B of the dash disassembly.



## Installation Manual Double DIN Kit

Part-No.: 381130-13

### • Honda CR-Z 2011->

Compatible with these Double-DIN devices:

#### Double-DIN Navigation

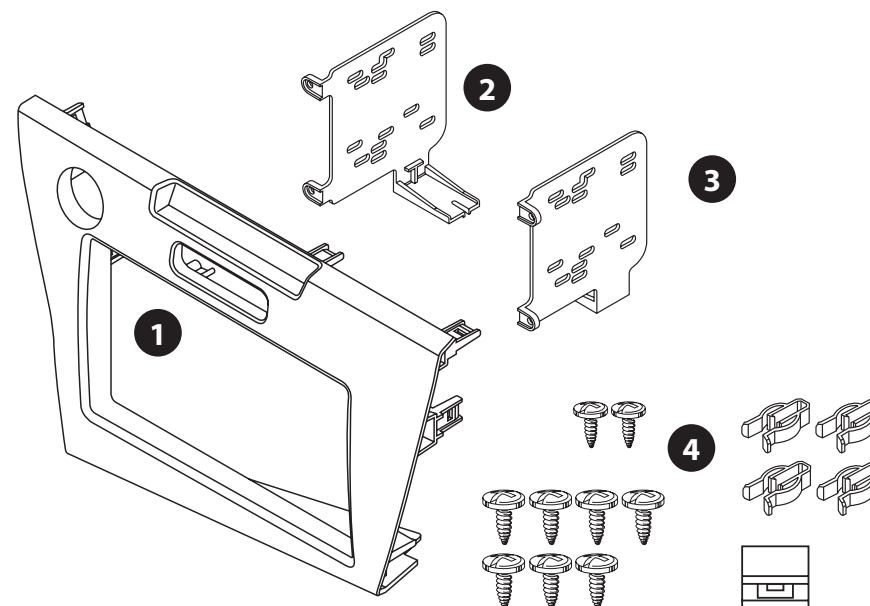

Double DIN Set contents  
• (1) Facia Plate

- (2) Mounting bracket (L)
- (3) Mounting bracket (R)
- (4) Installation accessories

# Installation Manual Double DIN Kit

1. Unclip and remove the lower dash panel cover above the pocket and remove the 8mm/Phillips screw. (Figures A and B)

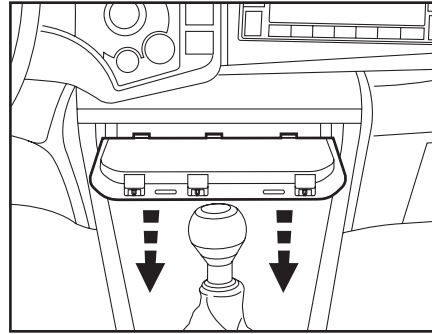

(Figure A)

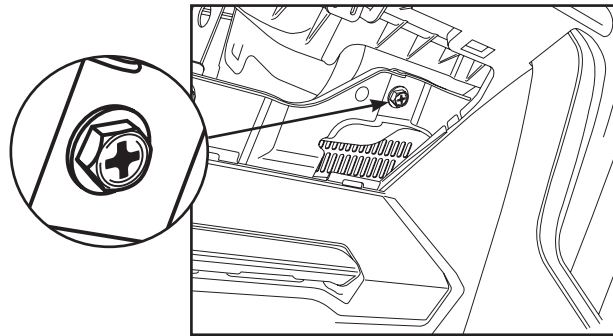

(Figure B)

2. Unclip and remove the radio from the dash. (Tip: start at the top of the radio) (Figure C)

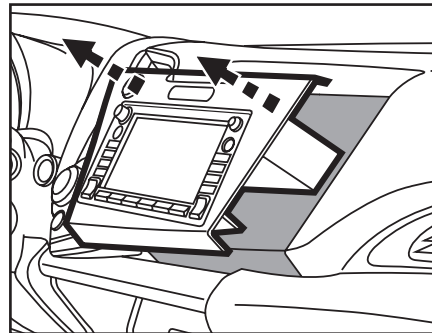

(Figure C)

3. Unplug and remove the radio.

1. Remove the center top clip off of the factory radio and install onto the double din facia plate

2. Follow the diagram to attach the necessary clips to the radio housing in the proper locations. (Figure A)

3. Remove 2 phillips screws holding the factory hazard switch for the factory panel and install into the double din facia plate re-using the factory hardware.

4. Remove 2 phillips screws holding the passenger airbag light from the factory panel and install into the facia plate using the supplied #6 screws.

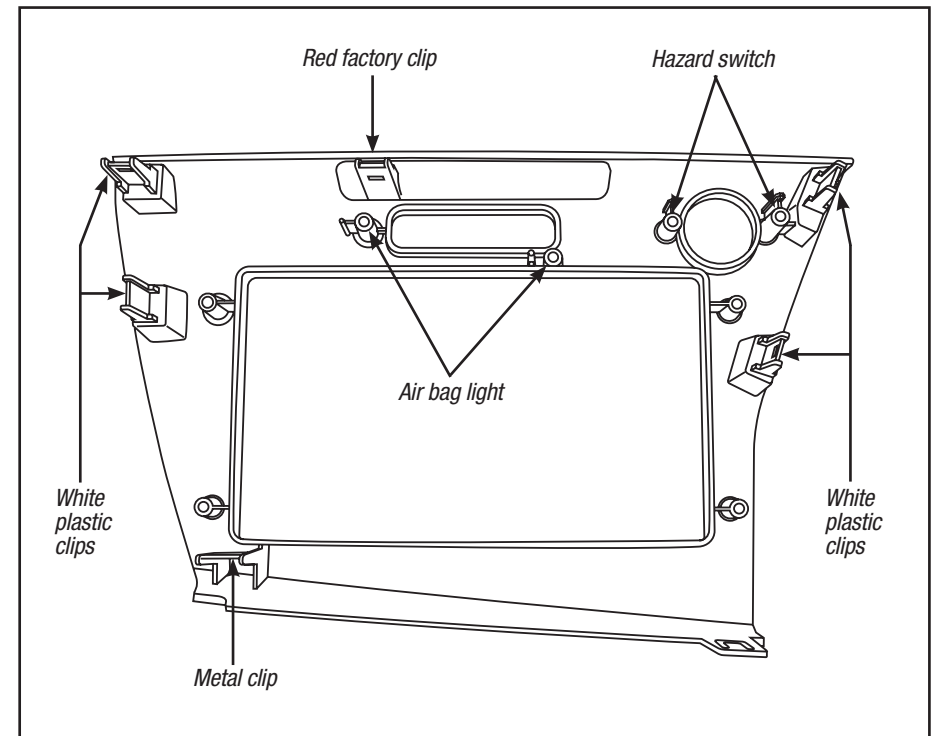

(Figure A)

All installation work must be performed by a qualified professional installer only.  
The manufacturer / dealer is not liable for any kind of incidental or indirect damages.