



## Installation Manual Double DIN Kit

colour: black	part-no.
2-DIN	381250-15-x
2-DIN with pocket	281250-15-x

**Nissan N400 2010->**  
**Opel Movano 2010->**  
**Renault Master III 2010->**

Compatible with these double DIN devices

### Double DIN Navigation

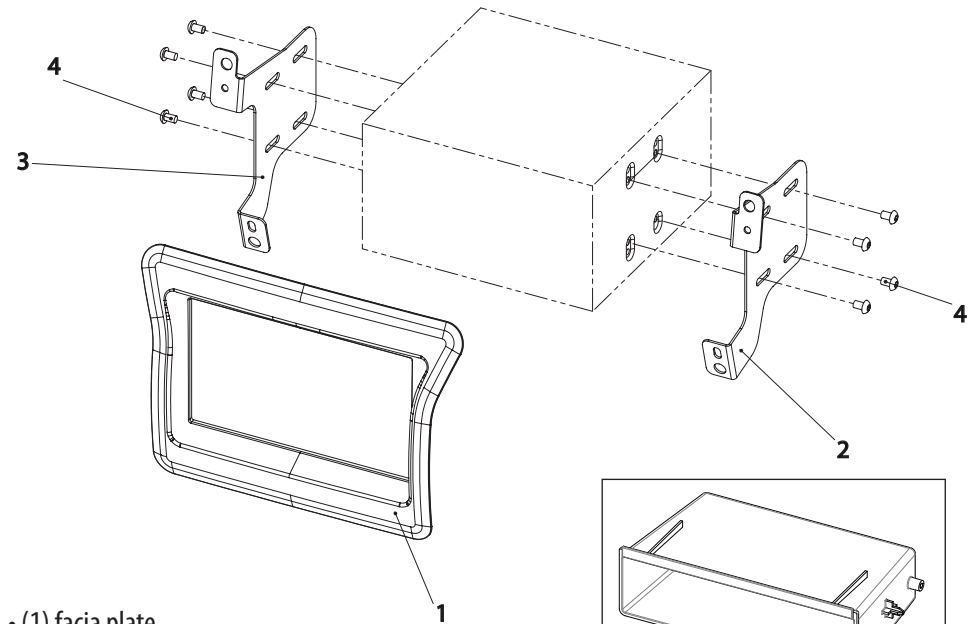

- (1) facia plate
- (2) metal frame right
- (3) metal frame left
- (4) flat headed screw

pocket (only 281250-15-x)



1. Sample dashboard photo with 1-DIN or OEM radio  
  
Remove radio with relase keys (unplug all connectors carefully)

---

---

---

---

---

---

---

---

---

---

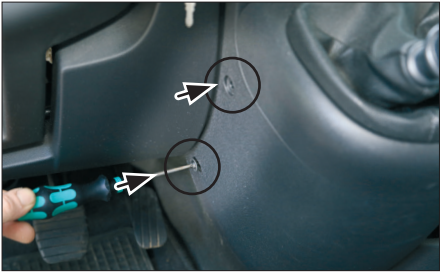

2. Remove 2 screws at the left side beside the shift knob

---

---

---

---

---

---

---

---

---

---

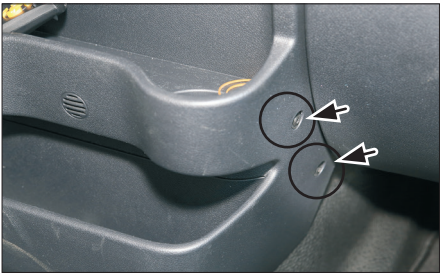

3. Remove 2 screws at the right side beside the cup holder unit

---

---

---

---

---

---

---

---

---

---



4. Pull panel with shift knob towards your direction. Remove 4 screws (see arrows)

---

---

---

---

---

---

---

---

---

---

- Fix new 2-DIN head unit  
Connect all required connectors

Plate center console  
Re-install everything in reverse  
order to finish installation



All installation work must be performed by a qualified professional installer only.  
The manufacturer / dealer is not liable for any kind of incidental or indirect damages.

© 09/2015 ALL RIGHTS RESERVED. Technical changes possible. No liability for misprints.



- Remove pocket  
above radio frame  
(unplug all connectors carefully)

Remove pocket at left side



- Remove screws at the right and  
left side behind radio frame



- Remove complete panel  
by pulling it towards your  
direction

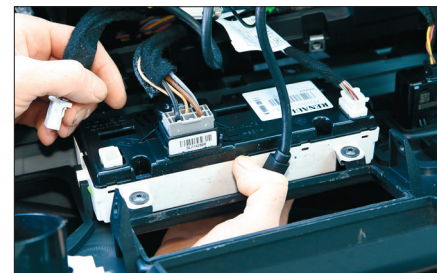

- Unplug all all connectors from  
the air condition control unit  
carefully

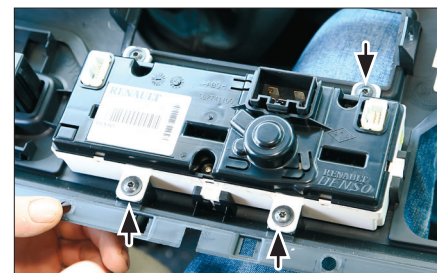

- Remove 4 screws of  
air condition control unit  
(see arrows)

Remove air condition  
control unit



10. Cut center bridge in order to clear space for 2-DIN facia plate



11. This bridge on the rear side of the OEM panel needs to be removed in order to attach the mounting brackets (see arrows)



12. Cut bridge on both sides in order to get a plain surface

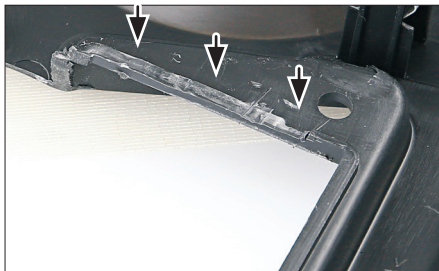

pre-assembly Brackets

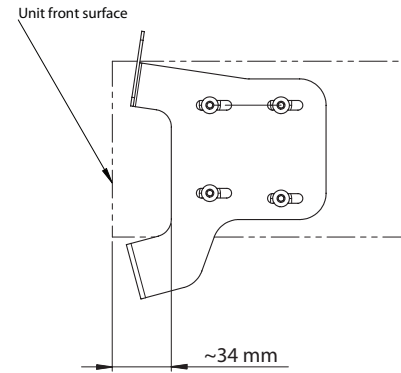

**2-DIN head unit**  
14a. Attach 2-DIN head unit to brackets\*  
We recommend a distance about **34 mm** (see graphic)

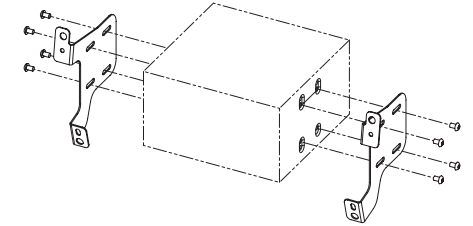

pre-assembly Brackets

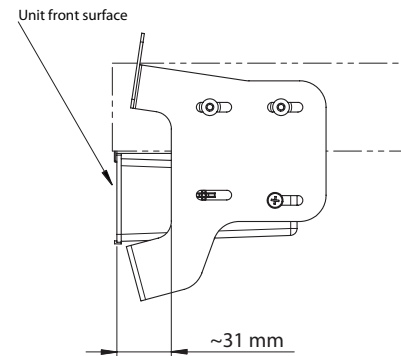

**1-DIN head unit**  
14b. Attach 1-DIN head unit and pocket to brackets\*  
We recommend a distance about **31 mm** (see graphic)

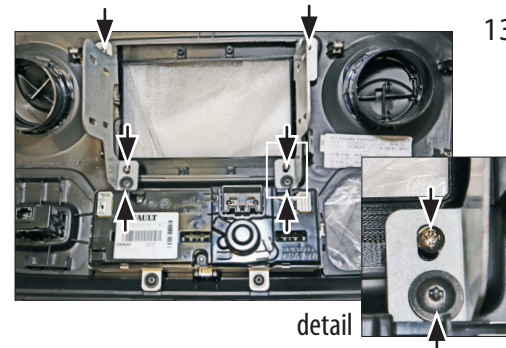
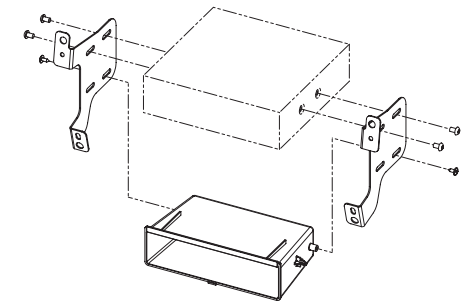

13. Attach air condition control unit to center cosole. Put metal frames over air condition control unit - attach 2-DIN facia plate

Fix everything with the appropriate screws